

DTMF decoder kit with relay output, opto coupled input & Morse transpond.

Our DTMF Opto decoder kit has one relay output offering clean contacts, and one Opto coupled input offering complete isolation from the circuit being monitored.

The output can be switched on/off remotely with or without a 4 digit security code. The decoder also has a TX keying output to key a transmitter for transponding a Morse confirmation. An audio output is included for the Morse audio tones. The PCB has been designed to allow 3 input configurations - unbalanced audio, an Electret microphone or balance audio to be connected.

The Opto input can be interrogated and a Morse confirmation received confirming the current state (on or off).

To turn the Output on/off send the decoder its ID followed by 0 and * for ON or # for OFF e.g. 12340* turns the output on and 12340# turns the output off.

To toggle the output send e.g. 12340A and the state of the output will be changed to the opposite of its previous state - the Morse transpond will be confirmation of the new state. To pulse the output send e.g. 12340B and the output will turn on for 0.5 seconds - the Morse transpond will be 0P.

You can use 9 for A and 8 for B with 12 key DTMF pad.

For confirmation of the switching of the output the decoder will key a Transmitter and respond in Morse code. Turning on the output will respond as 0 ON in Morse, and turning off the output will respond as 0 OFF. There is a 2 second transpond delay followed by a 400ms link establishment delay to allow for CTCSS (if used).



All parts shown in the assembled photo are included as well as some extras resistors for alternative input configuration.

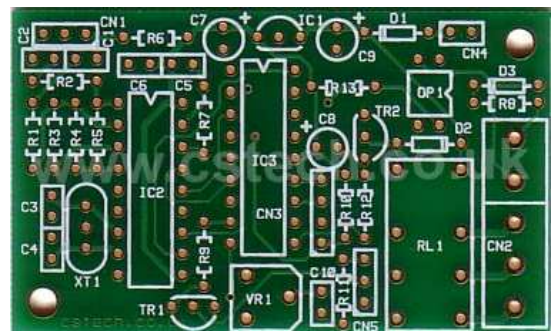

A circuit diagram is on the last page of this document.

A PDF datasheet for the HT9170 DTMF detector IC may be viewed at:

cstech.co.uk/ht9170.pdf

To interrogate the current state of the Opto 1 input send the ID followed by 1* e.g. 12341* and the decoder will transpond in Morse 1 OFF or 1 ON depending on the input state.

To interrogate the state of the output without changing it send the ID followed by 2* e.g. 12342*

The 4 digit security ID can be changed by simply fitting a jumper to the middle 2 pins of CN3, powering up the decoder and sending it a new 4 digit ID with DTMF, then remove power, remove jumper and power-up and the new ID is set. If no ID is required then simply program the ID as 0000 and on next power-up no ID will be needed and e.g. 0* will turn on the output.

There is also the ability to turn off the Morse transpond. When setting the 4 digit identity, add a fifth digit as 9 and the Morse transpond will be turned off. Any other character in the fifth position turns the Morse transpond on. When supplied the identity is supplied as 1234 and the fifth digit is set as 0. You do not need to program the fifth digit if transpond is desired; the fifth digit is not used as part of the identity.

The PCB is a high quality Gold Plated double sided PTH (plated through hole) 1.6mm FR4 (Fibreglass) board 64 x 38mm in size.

CN3 can also be used for in-circuit re-programming of the PIC with your own code.

There are many sources of DTMF, tone pads, two-way radio microphone keypads, telephone systems, and even your mobile phone's keypad tones.

As an example if using as a DTMF code lock, use a mobile phone's keypad tones and use the microphone option for pick up.

Applications include:-

- 1, DTMF remote control with relay O/P over radio or mobile phone, with input interrogation.
- 2, DTMF code lock etc.
- 3, Repeater remote shutdown.
- 4, Simple DTMF selcall.

Specification

Supply Voltage: 11 to 14V DC

Supply Current: ~10 to 40mA (relay Off / On)

Relay Contacts: 24V DC 1 Amp Max.

Opto input: 5 to 24V DC (reverse protected)

Audio input: See notes below

DTMF Opto Decoder Parts List

IC1	78L05
IC2	HT9170B
IC3	PIC16F627A (programmed)
OP1	FOD617D or FOD817
TR1, 2	BC184L
D1, 2, 3	1N4148
XT1	3.579MHz crystal
R1*	4K7
R2, 4	not fitted
R3*	270K
R5	wire link
R6*	1K
R7	330K
R8, 12	2K2
R9, 10, 11, 13	10K
VR1	10K variable
C1, 5, 6, 10	100nF (marked 104)
C2	not fitted
C3, 4	22pf
C7, 8, 9	1uF (marked 105) observe polarity
CN1, 5	3 pins
CN2	5 way terminal block (2 + 3 way)
CN4	2 Pins
CN3	4 Pins
RL1	BT47 style 12V relay

Also supplied:-

DTMF Opto PCB Issue A

1 x 0.1" jumper link

2 x 10K for alternative input configuration

Note:-

Only fit R6 if using an Electret microphone as input.

Only fit R1 and R3 as 4K7 and 270K for use with a microphone, otherwise fit R1 and R3 as 10K or calculate a custom configuration input from HT9170 datasheet.

DTMF Opto Decoder application notes follow.

There are 3 input configurations for our DTMF decoder, Electret microphone, un-balance and balanced, the 3 options are shown below in the circuit extracts. The HT9170 DTMF decoder chip has a wide input signal range from approx. 27mV to 775mV, but as it contains an op-amp at it's input and the op-amp gain can be altered using different resistor values, many combinations can be achieved.

Please see notes below:

The Electret microphone input version provides power to a microphone insert via R6 (1K) and using R1 at 4K7 and R3 at 270K to set the decoder chip's input op-amp gain to x57 the sensitivity allows pick-up from a DTMF tone pad at a couple of inches. A speaker phone, two-way radio speaker or the keypad tones from a mobile can be picked up 6 to 12 inches away.

We do not recommend increasing the input gain any higher.

Connect the microphone between pins 1 and 2 (2 = GND).

Resistors are provided in the kit for this option.

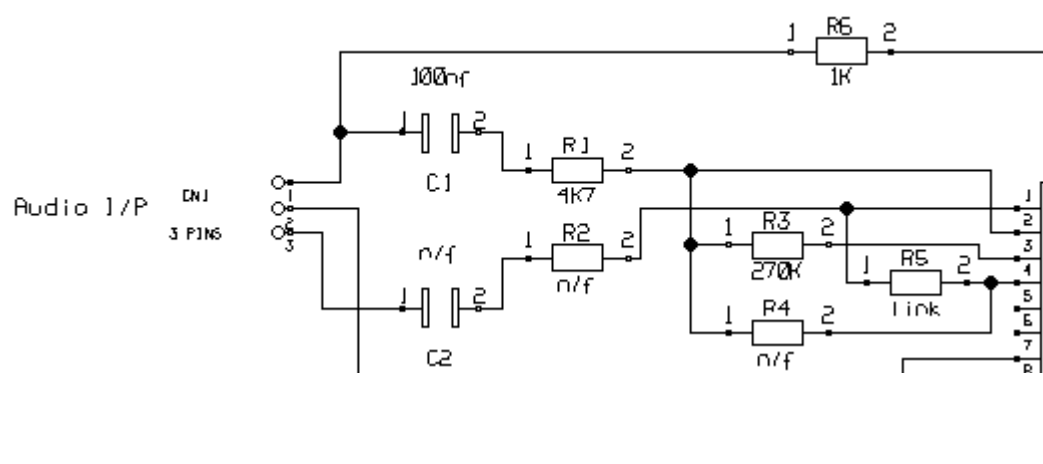

The following example offers an un-balanced audio input, using 10K resistors for R1 and R3 sets the decoder chip's input gain at x1 and gives an input impedance around 10K, R6 is omitted and this configuration can be fed directly from say the Packet modem RX audio output of a Ham radio.

If it is desired to change the input gain then increase R3 for higher gain and decrease R3 for lower gain.

Connect the signal source between pins 1 and 2 (2 = GND).

Resistors are provided in the kit for this option.

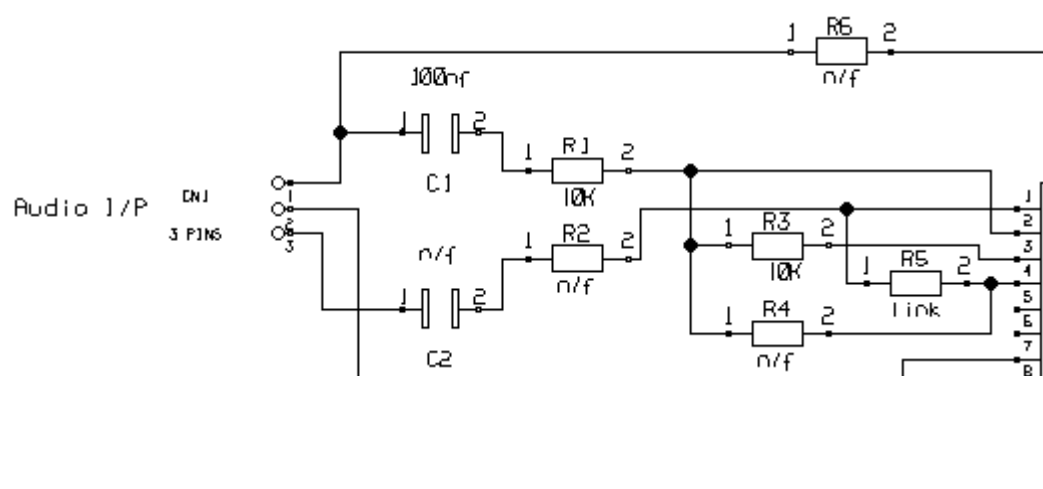

This example of a balanced audio input can be connected to say the earphone audio output of a GSM modem, with the values shown the decoder chip's input gain is also x1, however this can be changed as required, see the HT9170 data sheet (cstech.co.uk/ht9170.pdf) for the calculations.

Connect the signal source between pins 1 and 3.

Resistors are NOT supplied in the kit for this option as there are many combinations that could be required.

62K and 36K can be used instead of 60K and 37.5K

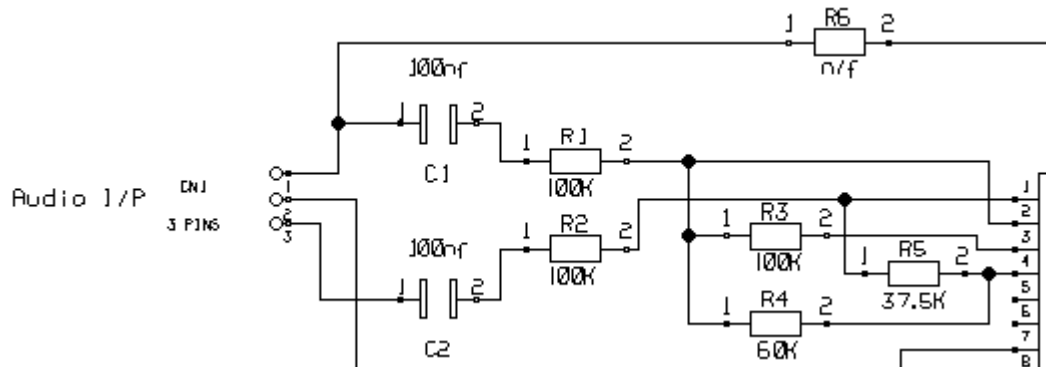

The open collector TX keying output is implemented with a BC184L NPN transistor; this output is intended to ground a radio transceiver's electronic PTT input.

The Morse audio output can be connected to a radio transceiver's Mic input or packet modem TX audio input, so that the Morse code response can be heard at the remote controlling radio. If using with a GSM modem this audio can be fed into the modems Mic input.

A variable resistor on the decoder allows for adjustment of the audio level, however if the adjustment is too close to the minimum end of the control, add a resistor in series with the audio output.

R1 & R3 set input op-amp gain
 C2, R2, R4 & R5 are for balanced input
 R6 = mic power feed option

